

## T-Cell Receptor Complex: TCR-CD3

The T-cell receptor associates with **CD3**, forming the TCR-CD3 membrane complex. In both cases, the accessory molecule participates in signal transduction *after* interaction of T cell with antigen; it does not influence interaction with antigen. CD3 is closely associated with the  $\alpha\beta$  heterodimer but also that its expression is required for membrane expression of  $\alpha\beta$  and  $\gamma\delta$  T-cell receptors each heterodimer forms a complex with CD3 on the T-cell membrane. CD3 is a complex of five invariant polypeptide chains that associate to form three dimers: a heterodimer of gamma and epsilon chains ( $\gamma\epsilon$ ), a heterodimer of delta and epsilon chains ( $\delta\epsilon$ ), and a homodimer of two zeta chains ( $\zeta\zeta$ ) or a heterodimer of zeta and eta chains ( $\zeta\eta$ ) (Figure 1). The  $\zeta$  and  $\eta$  chains are encoded by the same gene, but differ in their carboxyl-terminal ends because of differences in RNA splicing of the primary transcript. About 90% of the CD3 complexes examined to date incorporate the ( $\zeta\zeta$ ) homodimer; the remainder have the ( $\zeta\eta$ ) heterodimer. The T-cell receptor complex can thus be envisioned as four dimers: the  $\alpha\beta$  or  $\gamma\delta$  TCR heterodimer determines the ligand-binding specificity, whereas the CD3 dimers ( $\gamma\epsilon$ ,  $\delta\epsilon$ , and  $\zeta\zeta$  or  $\zeta\eta$ ) are required for membrane expression of the T-cell receptor and for signal transduction. The  $\gamma$ ,  $\epsilon$ , and  $\delta$  chains of CD3 are members of the immunoglobulin superfamily, each containing an immunoglobulin like extracellular domain followed by a transmembrane region and a cytoplasmic domain of more than 40 amino acids. The chain has a distinctly different structure, with a very short external region of only 9 amino acids, a transmembrane region, and a long cytoplasmic tail containing 113 amino acids. The transmembrane region of all the CD3 polypeptide chains contains a negatively charged aspartic acid residue that interacts with one or two positively charged amino acids in the transmembrane region of each TCR chain. The cytoplasmic tails of the CD3 chains contain a motif called the **immunoreceptor tyrosine-based activation motif (ITAM)**. ITAMs are found in a number of other receptors, including the Ig- $\alpha$ /Ig- $\beta$  heterodimer of the B-cell receptor complex and the Fc receptors for IgE and IgG. The ITAM sites have been shown to interact with tyrosine kinases and to play an important role in signal transduction. In CD3, the  $\gamma$ ,  $\delta$ , and  $\epsilon$  chains each contain a single copy of ITAM, whereas the  $\zeta$  and  $\eta$  chains contain three copies (see Figure 1).

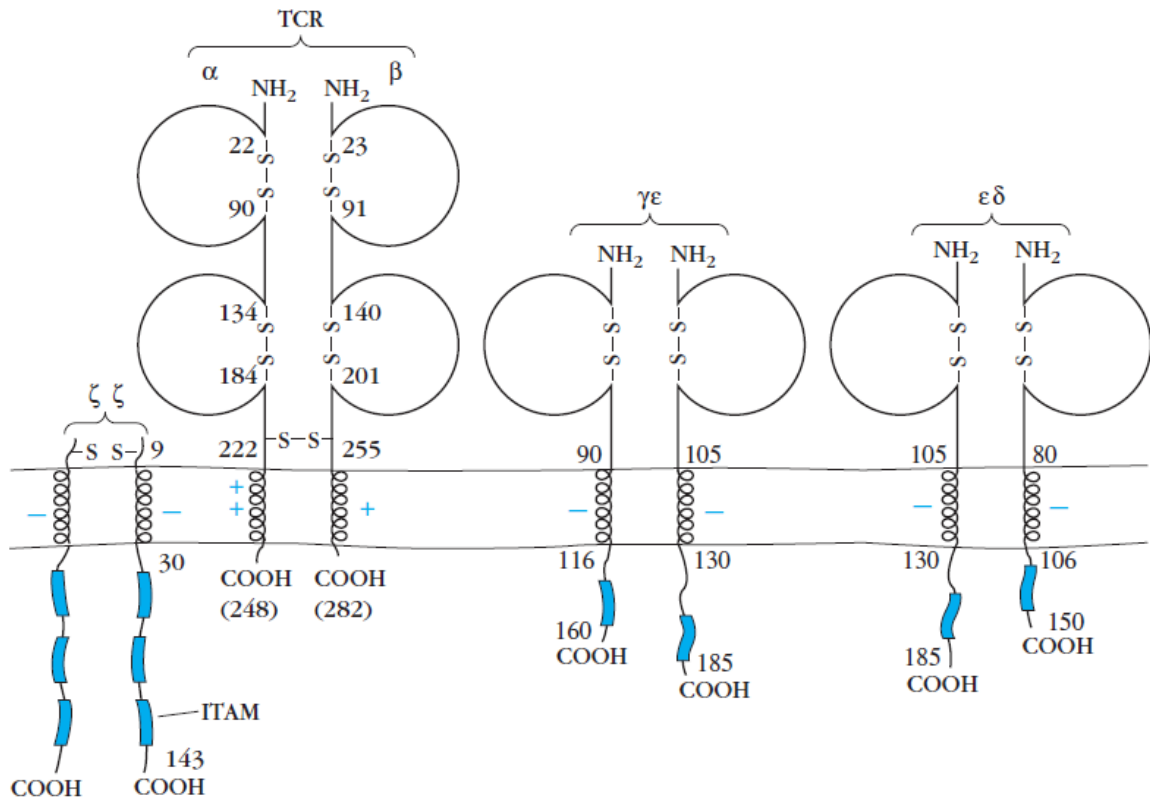

Figure1: Schematic diagram of the TCR-CD3 complex, which constitutes the T-cell antigen-binding receptor. The CD3 complex consists of the homodimer  $\zeta\zeta$  (alternately, a  $\zeta\eta$  heterodimer) plus  $\gamma\epsilon$  and  $\delta\epsilon$  heterodimers. The external domains of the  $\gamma$ ,  $\delta$ , and  $\epsilon$  chains of CD3 are similar to the immunoglobulin fold, which facilitates their interaction with the T-cell receptor and each other. Ionic interactions also may occur between the oppositely charged transmembrane regions in the TCR and CD3 chains. The long cytoplasmic tails of the CD3 chains contain a common sequence, the immunoreceptor tyrosine-based activation motif (ITAM), which functions in signal transduction.

## T-Cell Accessory Membrane Molecules

### CD4 and CD8 Coreceptors Bind to Conserved Regions of MHC Class II or I Molecules.

T cells can be subdivided into two populations according to their expression of CD4 or CD8 membrane molecules. CD4 is a 55-kDa monomeric membrane glycoprotein that contains four extracellular immunoglobulin-like domains (D1–D4), a hydrophobic transmembrane region, and a long cytoplasmic tail (Figure 2) containing three serine residues that can be phosphorylated. CD8 generally takes the form of a disulfide linked  $\alpha\beta$  heterodimer or of an  $\alpha\alpha$

homodimer. Both the  $\alpha$  and  $\beta$  chains of CD8 are small glycoproteins of approximately 30–38 kDa. Each chain consists of a single extracellular immunoglobulin-like domain, a hydrophobic transmembrane region, and a cytoplasmic tail (Figure 2) containing 25–27 residues, several of which can be phosphorylated. CD4 and CD8 are classified as *coreceptors* based on their abilities to recognize the peptide-MHC complex and their roles in signal transduction. The extracellular domains of CD4 and CD8 bind to the conserved regions of MHC molecules on antigen-presenting cells (APCs) or target cells.

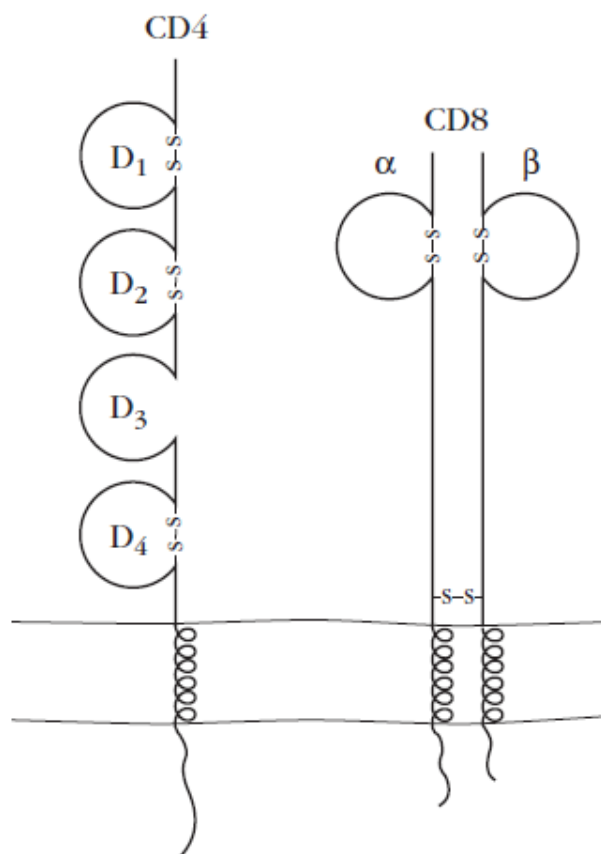

Figure2: General structure of the CD4 and CD8 coreceptors. CD8 may take the form of an  $\alpha\beta$  heterodimer, or an  $\alpha\alpha$  homodimer. The monomeric CD4 molecule contains four Ig-fold domains; each chain in the CD8 molecule contains one.

However, T-cell interactions do not depend solely on binding by the TCR; *cell-adhesion molecules* strengthen the bond between a T cell and an antigen-presenting cell or a target cell.

Several accessory membrane molecules, including CD2, LFA-1, CD28, and CD45R bind independently to other ligands on antigen-presenting cells or target cells. Once cell-to-cell contact has been made by the adhesion molecules, the T-cell receptor may scan the membrane for peptide-MHC complexes. During activation of a T cell by a particular peptide-MHC complex, there is a transient increase in the membrane expression of cell-adhesion molecules, causing closer contact between the interacting cells, which allows cytokines or cytotoxic substances to be transferred more effectively. Soon after activation, the degree of adhesion declines and the T cell detaches from the antigen-presenting cell or target cell. Like CD4 and CD8, some of these other molecules also function as signal-transducers.

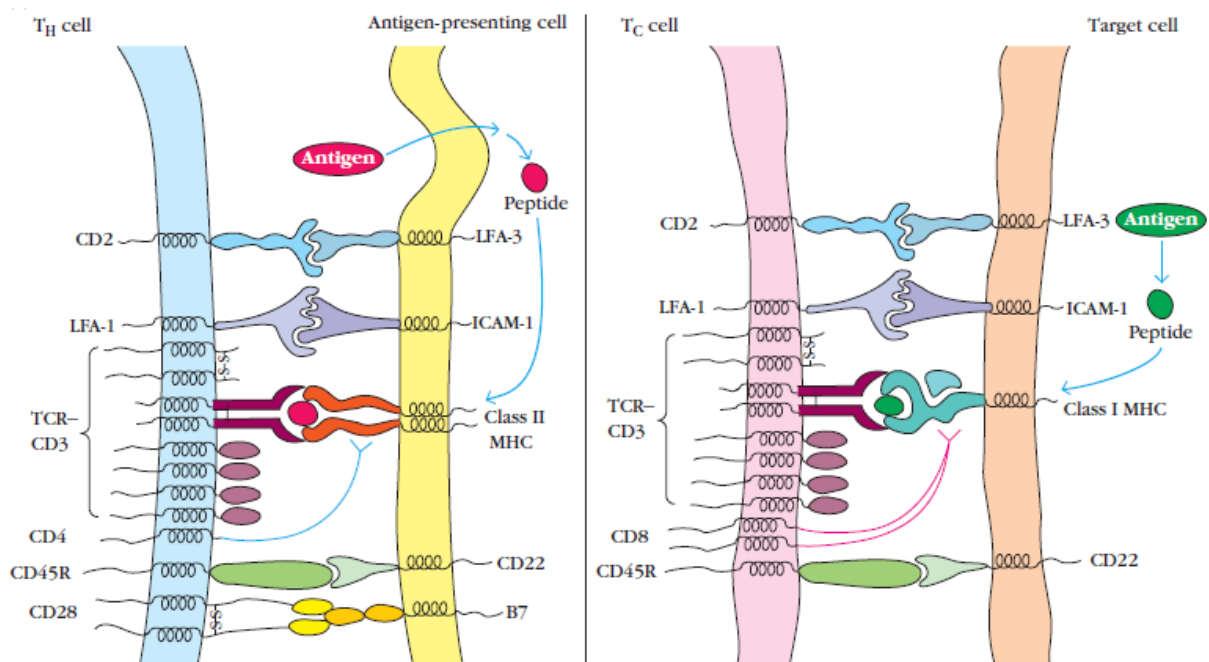

Figure 3: Role of coreceptors in TCR binding affinity. (a) Affinity constants for various biologic systems. (b) Schematic diagram of the interactions between the T-cell receptor and the peptide-MHC complex and of various accessory molecules with their ligands on an antigen-presenting cell (*left*) or target cell (*right*). Binding of the coreceptors CD4 and CD8 and the other accessory molecules to their ligands strengthens the bond between the interacting cells and/or facilitates the signal transduction that leads to activation of the T cell.