

4.2 Design of Sections for Flexure

This section covers the following topics

- Preliminary Design
- Final Design for Type 1 Members
- Special Case

Calculation of Moment Demand

For simply supported prestressed beams, the maximum moment at the span is given by the beam theory. For continuous prestressed beams, the analysis can be done by moment distribution method. The moment coefficients in **Table 12** of **IS:456 - 2000** can be used under conditions of uniform cross-section of the beams, uniform loads and similar lengths of span.

The design is done for the critical section. For a simply supported beam under uniform loads, the critical section is at the mid span. For a continuous beam, there are critical sections at the supports and at the spans.

For design under service loads, the following quantities are known.

M_{DL} = moment due to dead load (excluding self-weight)

M_{LL} = moment due to live load.

The material properties are selected before the design.

The following quantities are unknown.

The member cross-section and its geometric properties,

M_{SW} = moment due to self-weight,

A_p = amount of prestressing steel,

P_e = the effective prestress,

e = the eccentricity.

There are two stages of design.

- 1) **Preliminary**: In this stage the cross-section is defined and P_e and A_p are estimated.

- 2) **Final:** The values of e (at the critical section), P_e , A_p and the stresses in concrete at transfer and under service loads are calculated. The stresses are checked with the allowable values. The section is modified if required.

4.2.1 Preliminary Design

The steps of preliminary design are as follows.

- 1) Select the material properties f_{ck} and f_{pk} .
- 2) Determine the total depth of beam (h).

The total depth can be based on architectural requirement or, the following empirical equation can be used.

$$h = 0.03 \sqrt{M} \text{ to } 0.04 \sqrt{M} \quad (4-2.1)$$

Here, h is in meters and M is in kNm. M is the total moment excluding self-weight.

- 3) Select the type of section. For a rectangular section, assume the breadth $b = h/2$.
- 4) Calculate the self-weight or, estimate the self-weight to be 10% to 20% of the load carried.
- 5) Calculate the total moment M_T including self-weight. The moment due to self-weight is denoted as M_{sw} .
- 6) Estimate the lever arm (z).
 $z \approx 0.65h$, if M_{sw} is large ($M_{sw} > 0.3M_T$).
 $z \approx 0.5h$, if M_{sw} is small.
- 7) Estimate the effective prestress (P_e)
 $P_e = M_T / z$, if M_{sw} is large.
 $P_e = M_{IL} / z$, if M_{sw} is small.

If M_{sw} is small, the design is governed by the moment due to imposed load

($M_{IL} = M_T - M_{sw}$).

- 8) Considering $f_{pe} = 0.7f_{pk}$, calculate area of prestressing steel $A_p = P_e / f_{pe}$.
- 9) Check the area of the cross-section (A).

The average stress in concrete at service $C/A (= P_e / A)$ should not be too high as compared to 50% of the allowable compressive stress $f_{cc,all}$. If it is so, increase the area of the section to $A = P_e / (0.5f_{cc,all})$.

4.2.2 Final Design for Type 1 Members

The code **IS:1343 - 1980** defines three types of prestressed members.

Type 1: In this type of members, no tensile stress is allowed in concrete at transfer or under service loads.

Type 2: In these members, tensile stress is within the cracking stress of concrete.

Type 3: Here, the tensile stress is such that the crack width is within the allowable limit.

The final design involves the checking of the stresses in concrete at transfer and under service loads with respect to the allowable stresses. Since the allowable stresses depend on the type of member (Type 1, Type 2 or Type 3), the equations vary for the different types. Here, the steps of final design are explained for Type 1 members. The steps for Type 2 members are explained in Section 4.3, Design of Sections for Flexure (Part II). The steps for Type 3 members are similar to Type 2, the only difference being the value of the allowable tensile stress in concrete.

For small moment due to self-weight ($M_{sw} \leq 0.3M_T$), the steps are as follows.

1) Calculate eccentricity e to locate the centroid of the prestressing steel (CGS).

With increasing load, the compression (C) moves upward from the location of the tension (T) at CGS. At transfer, under the self-weight, C should lie within the kern zone to avoid tensile stress at the top. The kern points and kern zone are explained in Section 3.3, Analysis of Member under Flexure (Part II).

The lowest permissible location of C due to self-weight is at the bottom kern point (at a depth k_b below CGC) to avoid tensile stress at the top. The design procedure based on the extreme location of C gives an economical section.

The following sketch explains the lowest permissible location of C due to self-weight moment (M_{sw}) at transfer.

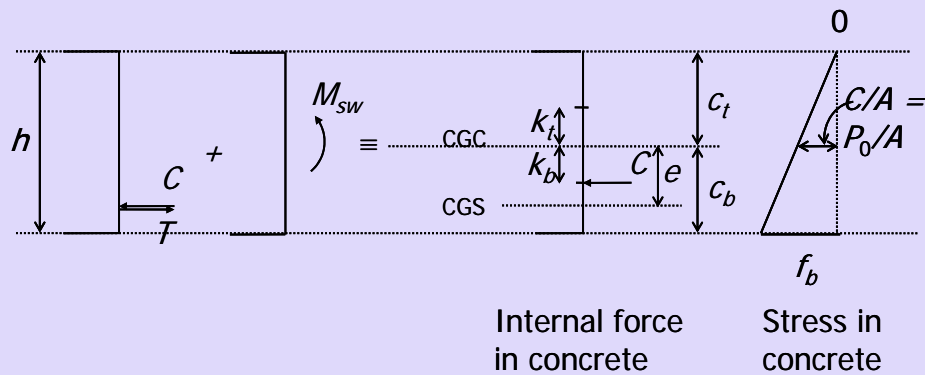

Figure 4-2.1 Stress in concrete due to compression at bottom kern point

In the above sketch,

- A = gross area of cross section
- f_b = maximum compressive stress in concrete at bottom edge
- h = total height of the section
- k_t, k_b = distances of upper and lower kern points, respectively, from CGC
- c_t, c_b = distances of upper and lower edges, respectively, from CGC
- P_0 = prestress at transfer after initial losses.

The shift of C due to self-weight gives an expression of e .

$$e = (M_{sw} / P_0) + k_b \quad (4-2.2)$$

Here, the magnitude of C or T is equal to P_0 . The value of P_0 can be estimated as follows.

- a) 90% of the initial applied prestress (P_i) for pre-tensioned members.
- b) Equal to P_i for post-tensioned members.

The value of P_i can be estimated from the amount of prestressing steel determined in the preliminary design.

$$P_i = A_p(0.8f_{pk}) \quad (4-2.3)$$

Here, the permissible prestress in the steel is $0.8f_{pk}$, where f_{pk} is the characteristic tensile strength.

2) Recompute the effective prestress P_e and the area of prestressing steel A_p .

With increasing load, C further moves up. Under the service loads, C should lie within the kern zone to avoid tensile stress at the bottom. The highest permissible location of

C due to total load is at the top kern point (at a height k_t above CGC) to avoid tensile stress at the bottom.

The following sketch explains the highest possible location of C due to the total moment (M_T).

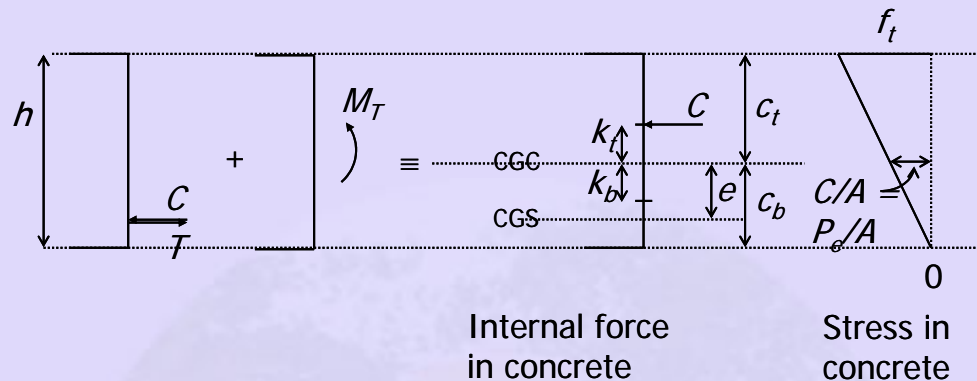

Figure 4-2.2 Stress in concrete due to compression at top kern point

In the above sketch,

f_t = maximum compressive stress in concrete at top edge.

The shift of C due to the total moment gives an expression of P_e .

$$P_e = M_T / (e + k_t) \quad (4-2.4)$$

Considering $f_{pe} = 0.7f_{pk}$, the area of prestressing steel is recomputed as follows.

$$A_p = P_e / f_{pe} \quad (4-2.5)$$

3) Recompute eccentricity e

First the value of P_0 is updated. The eccentricity e is recomputed with the updated value of P_0 .

If the variation of e from the previous value is large, another cycle of computation of the prestressing variables can be undertaken.

4) Check the compressive stresses in concrete.

The maximum compressive stress in concrete should be limited to the allowable values.

At transfer, the stress at the bottom should be limited to $f_{cc,all}$, where $f_{cc,all}$ is the allowable compressive stress in concrete at transfer (available from **Figure 8** of **IS:1343**

- 1980). At service, the stress at the top should be limited to $f_{cc,all}$, where $f_{cc,all}$ is the allowable compressive stress in concrete under service loads (available from **Figure 7** of **IS:1343 - 1980**).

a) At Transfer

The stress at the bottom can be calculated from the average stress $-P_0/A$.

$$f_b = -\frac{P_0 h}{A c_t} \quad (4-2.6)$$

To satisfy $|f_b| \leq f_{cc,all}$, the area of the section (A) is checked as follows.

$$A \geq \frac{P_0 h}{f_{cc,all} c_t} \quad (4-2.7)$$

If A is not adequate then the section has to be redesigned.

b) At Service

The stress at the top can be calculated from the average stress $-P_e/A$.

$$f_t = -\frac{P_e h}{A c_b} \quad (4-2.8)$$

To satisfy $|f_t| \leq f_{cc,all}$, the area of the section (A) is checked as follows.

$$A \geq \frac{P_e h}{f_{cc,all} c_b} \quad (4-2.9)$$

If A is not adequate then the section has to be redesigned.

4.2.3 Special Case

For large moment due to self-weight ($M_{sw} > 0.3 M_T$), the eccentricity e according to $e = (M_w / P_0) + k_b$ may violate the cover requirements or, may even lie outside the beam. In such cases, locate e as per cover requirements. The location of C at transfer will be within the kern zone without zero stress at the top. The expression of stress at the bottom is different from that given earlier. The other steps are same as before.

At transfer, the stress at the bottom is calculated using the following stress profile.

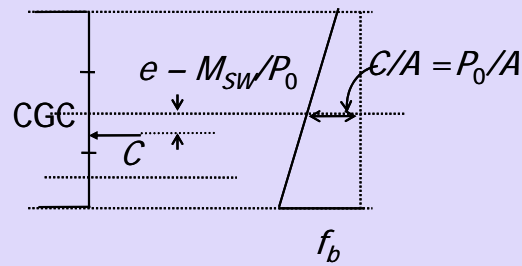

Figure 4-2.3 Stress in concrete due to compression above bottom kern point

$$f_b = -\frac{P_0}{A} - \frac{P_0 \left(e - \frac{M_{SW}}{P_0} \right) c_b}{I} \quad (4-2.10)$$

Substituting $I = Ar^2$ and $r^2/c_b = k_t$

$$f_b = -\frac{P_0}{A} \left(1 + \frac{e - \frac{M_{SW}}{P_0}}{k_t} \right) \quad (4-2.11)$$

To satisfy $|f_b| \leq f_{cc,all}$, the area of the section (A) is checked as follows.

$$A \geq \frac{P_0}{f_{cc,all}} \left(1 + \frac{e - \frac{M_{SW}}{P_0}}{k_t} \right) \quad (4-2.12)$$

The following example shows the design of a Type 1 prestressed member.

Example 4-2.1

Design a simply supported Type 1 prestressed beam with $M_T = 435$ kNm (including an estimated $M_{SW} = 55$ kNm). The height of the beam is restricted to 920 mm. The prestress at transfer $f_{p0} = 1035$ N/mm² and the prestress at service $f_{pe} = 860$ N/mm².

Based on the grade of concrete, the allowable compressive stresses are 12.5 N/mm² at transfer and 11.0 N/mm² at service.

The properties of the prestressing strands are given below.

Type of prestressing tendon : 7-wire strand

Nominal diameter = 12.8 mm

Nominal area = 99.3 mm²

Solution

A) Preliminary design

The values of h and M_{SW} are given.

1) Estimate lever arm z .

$$\frac{M_{sw}}{M_T} = \frac{55}{435}$$

$$= 12.5 \%$$

Since $M_{SW} < 0.3 M_T$,

Use $z = 0.5h$

$$= 0.5 \times 920$$

$$= 460 \text{ mm}$$

2) Estimate the effective prestress.

Moment due to imposed loads

$$M_{IL} = M_T - M_{sw}$$

$$= 435 - 55$$

$$= 380 \text{ kNm}$$

Effective prestress

$$P_e = \frac{380 \times 10^3}{460}$$

$$= 826 \text{ kN}$$

3) Estimate the area of the prestressing steel.

$$A_p = \frac{P_e}{f_{pe}}$$

$$= \frac{826 \times 10^3}{860}$$

$$= 960 \text{ mm}^2$$

4) Estimate the area of the section to have average stress in concrete equal to $0.5 f_{cc,all}$.

$$\begin{aligned} A &= \frac{P_e}{0.5 f_{cc,all}} \\ &= \frac{826 \times 10^3}{0.5 \times 11.0} \\ &= 150 \times 10^3 \text{ mm}^2 \end{aligned}$$

The following trial section has the required depth and area.

Trial cross-section

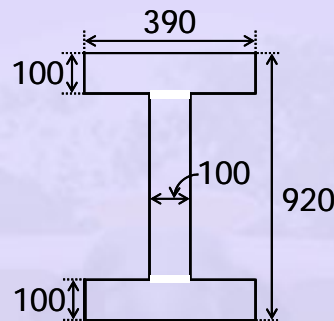

Values in mm.

B) Calculation of geometric properties

The section is symmetric about the horizontal axis. Hence, the CGC lies at mid depth. The section is divided into three rectangles for the computation of the geometric properties.

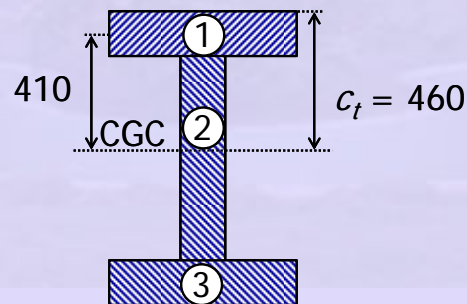

Values in mm.

Check area of the section

$$\begin{aligned} A &= 2A_1 + A_2 \\ &= 2 \times (390 \times 100) + (720 \times 100) \\ &= 150,000 \text{ mm}^2 \end{aligned}$$

Moment of inertia of the section about axis through CGC

$$\begin{aligned}
 I &= 2I_1 + I_2 \\
 &= 2 \left[\frac{1}{12} \times 390 \times 100^3 + (390 \times 100) \times 410^2 \right] + \frac{1}{12} \times 100 \times 720^3 \\
 &= 1.6287 \times 10^{10} \text{ mm}^4
 \end{aligned}$$

Square of the radius of gyration

$$\begin{aligned}
 r^2 &= \frac{I}{A} \\
 &= \frac{1.6287 \times 10^{10}}{150,000} \\
 &= 108,580 \text{ mm}^2
 \end{aligned}$$

Kern levels of the section

$$\begin{aligned}
 k_t = k_b &= \frac{r^2}{c_t} \\
 &= \frac{108,580}{460} \\
 &= 236 \text{ mm}
 \end{aligned}$$

Summary after preliminary design

Properties of section

$$A = 150,000 \text{ mm}^2$$

$$I = 1.6287 \times 10^{10} \text{ mm}^4$$

$$c_t = c_b = 460 \text{ mm}$$

$$k_t = k_b = 236 \text{ mm}$$

Properties of prestressing steel

$$A_p = 960 \text{ mm}^2$$

$$P_e = 826 \text{ kN}$$

C) Final design

 1) Calculate eccentricity e

$$\begin{aligned} P_0 &= A_p f_{p0} \\ &= 960 \times 1035 \\ &= 993.6 \text{ kN} \end{aligned}$$

$$\begin{aligned} e &= \frac{M_{sw}}{P_0} + k_b \\ &= \frac{55.0 \times 10^3}{993.6} + 236 \\ &\approx 290 \text{ mm} \end{aligned}$$

2) Recompute the effective prestress and associated variables.

$$\begin{aligned} P_e &= \frac{M_T}{e + k_t} \\ &= \frac{435 \times 10^3}{(290 + 236)} \\ &= 827 \text{ kN} \end{aligned}$$

Since P_e is very close to the previous estimate of 826 kN, A_p , P_0 and e remain same.

The tendons are placed in two ducts. The outer diameter of each duct is 54 mm.

Select (10) 7-wire strands with

$$\begin{aligned} A_p &= 10 \times 99.3 \\ &= 993.0 \text{ mm}^2 \end{aligned}$$

3) Check the compressive stresses in concrete.

a) At transfer

$$\begin{aligned} A &\geq \frac{P_0 h}{f_{cc,all} c_t} \\ &= \frac{993.6 \times 920}{12.5 \times 460} \\ &= 158,976 \text{ mm}^2 \end{aligned}$$

b) At service

$$\begin{aligned} A &\geq \frac{P_e h}{f_{cc,all} c_b} \\ &= \frac{827 \times 920}{11.0 \times 460} \\ &= 150,364 \text{ mm}^2 \end{aligned}$$

The governing value of A is $158,976 \text{ mm}^2$. The section needs to be revised. The width of the flange is increased to 435 mm . The area of the revised section is $159,000 \text{ mm}^2$.

Another set of calculations can be done to calculate the geometric properties precisely.

Designed cross-section at mid-span

