

3.5 Analysis of Members under Flexure (Part IV)

This section covers the following topics.

- Analysis of a Flanged Section

3.5.1 Analysis of a Flanged Section

Introduction

A beam can have flanges for flexural efficiency. There can be several types of flanged section.

- 1) A precast or cast-in-place flanged section, with flanges either at top or bottom or at both top and bottom.
- 2) A composite flanged section is made of precast web and cast-in-place slab.

The following figures show different types of flanged sections.

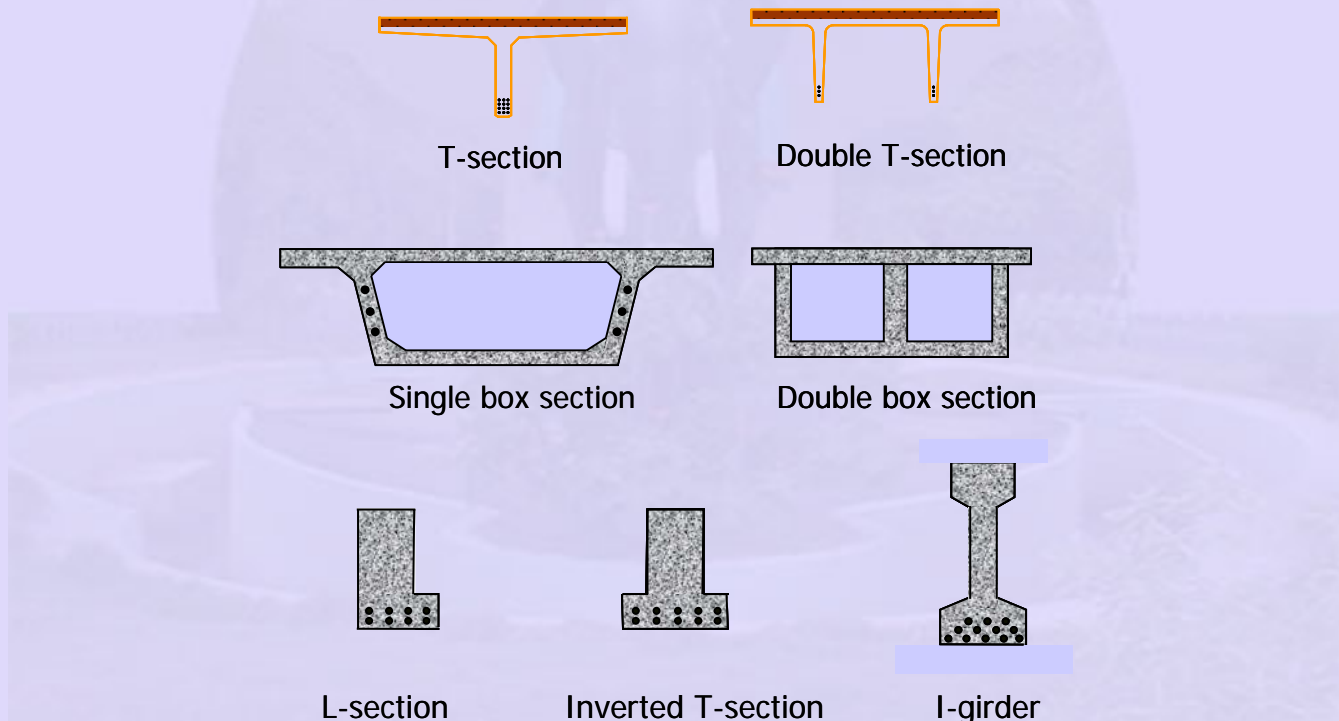

Figure 3-5.1 Examples of precast flanged sections

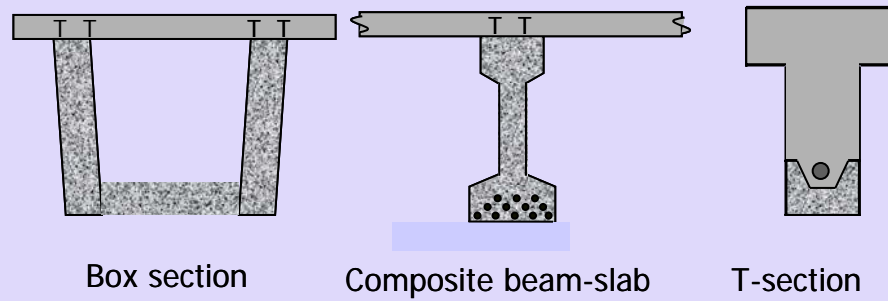

Figure 3-5.2 Examples of composite flanged sections

The analysis of a flanged section for ultimate strength is different from a rectangular section when the flange is in compression. If the depth of the neutral axis from the edge under compression is greater than the depth of the flange, then the section is treated as a flanged section. In the following figure, the first strain profile shows that the depth of the neutral axis (x_u) is greater than the depth of the flange (D_f). The section is treated as a flanged section.

The second strain profile shows that x_u is less than D_f . In this situation, the section can be treated as a rectangular section.

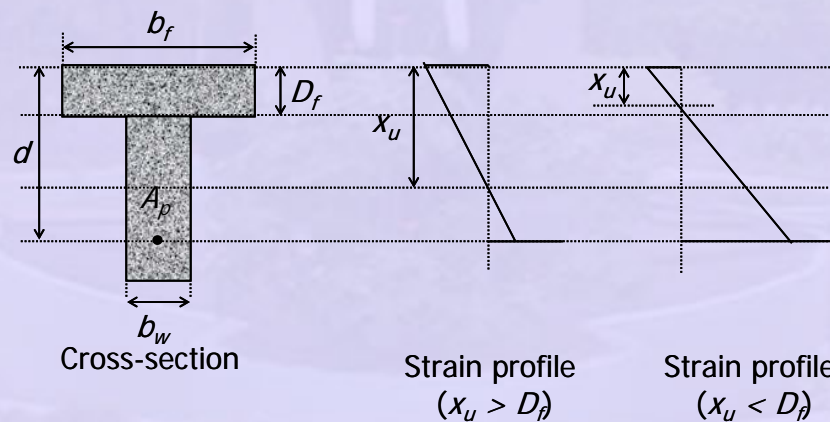

Figure 3-5.3 Two possibilities of strain profile in a flanged section

The effective width or breadth of the flange (b_f) is determined from the span of the beam, breadth of the web (b_w) and depth of the flange (D_f) as per **Clause 23.1.2, IS:456 - 2000**.

Analysis of a Flanged Section

The following sketch shows the beam cross-section, strain profile, stress diagram and force couples at the ultimate state. The following conditions are considered.

- 1) $x_u > D_f$: This requires an analysis for a flanged section.

- 2) $D_f \leq (3/7) x_u$: This ensures that the compressive stress is constant at $0.447f_{ck}$ along the depth of the flange.

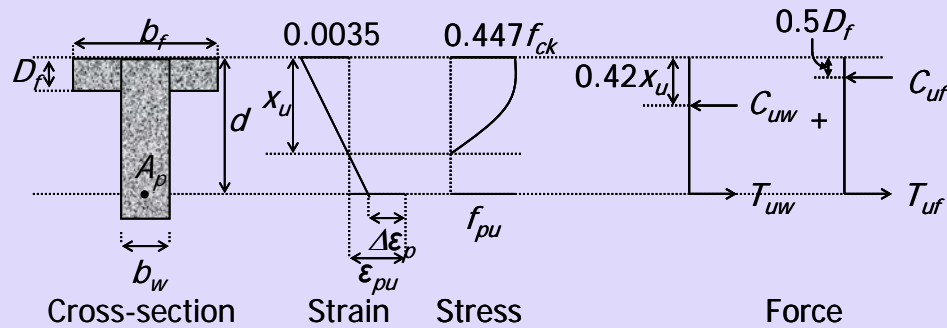

Figure 3-5.4 Sketches for analysis of a flanged section

The variables in the above figure are explained.

- b_f = breadth of the flange
- b_w = breadth of the web
- D_f = depth of the flange
- d = depth of the centroid of prestressing steel (CGS)
- A_p = area of the prestressing steel
- $\Delta\epsilon_p$ = strain difference in the prestressing steel when strain in concrete is zero
- x_u = depth of the neutral axis at ultimate
- ϵ_{pu} = strain in prestressing steel at the level of CGS at ultimate
- f_{pu} = stress in prestressing steel at ultimate

The strain difference ($\Delta\epsilon_p$) is further explained in Section 3.4, Analysis of Member under Flexure (Part III).

In the sketch, the tensile force is decomposed into two components. The first component (T_{uw}) balances the compressive force carried by the web, including the portion of the flange above web (C_{uw}). Thus $T_{uw} = C_{uw}$. The second component (T_{uf}) balances the compressive force carried by the outstanding portion of the flange (C_{uf}). Thus $T_{uf} = C_{uf}$.

The stress block in concrete is derived from the constitutive relationship for concrete. The relationship is explained in Section 1.6, Concrete (Part II). The compressive force in concrete can be calculated by integrating the stress block along the depth. The

stress in the tendon is calculated from the constitutive relationship for prestressing steel. The relationship is explained in Section 1.7, Prestressing Steel.

The expressions of the forces are as follows.

$$C_{uw} = 0.36f_{ck}x_u b_w \quad (3-5.1)$$

$$C_{uf} = 0.447f_{ck}(b_f - b_w)D_f \quad (3-5.2)$$

$$T_{uw} = A_{pw}f_{pu} \quad (3-5.3)$$

$$T_{uf} = A_{pf}f_{pu} \quad (3-5.4)$$

The strengths of the materials are denoted by the following symbols.

A_{pf} = part of A_p that balances compression in the outstanding flanges

A_{pw} = part of A_p that balances compression in the web

f_{ck} = characteristic compressive strength of concrete

f_{pk} = characteristic tensile strength of prestressing steel

Based on the principles of mechanics (as explained under the Analysis of a Rectangular Section in Section 3.4, Analysis of Member Under Flexure (Part III)), the following equations are derived.

1) Equations of equilibrium

The first equation states that the resultant axial force is zero. This means that the compression and the tension in the force couple balance each other.

$$\begin{aligned} \sum F &= 0 \\ \Rightarrow T_u &= C_u \\ \Rightarrow T_{uw} + T_{uf} &= C_{uw} + C_{uf} \\ \Rightarrow (A_{pw} + A_{pf})f_{pu} &= 0.36 f_{ck}x_u b_w + 0.447 f_{ck}(b_f - b_w)D_f \end{aligned} \quad (3-5.5)$$

The second equation relates the ultimate moment capacity (M_{uR}) with the internal couple in the force diagram.

$$\begin{aligned} M_{uR} &= T_{uw}(d - 0.42x_u) + T_{uf}(d - 0.5D_f) \\ &= A_{pw}f_{pu}(d - 0.42x_u) + A_{pf}f_{pu}(d - 0.5D_f) \end{aligned} \quad (3-5.6)$$

From $T_{uf} = C_{uf}$ and Eqns. (3-5.2) and (3-5.4), A_{pf} is given as follows. The calculation of A_{pw} from A_p and A_{pf} is also shown.

$$A_{pf} = \frac{0.447f_{ck}(b_f - b_w)D_f}{f_{pu}} \quad (3-5.7)$$

$$A_{pw} = A_p - A_{pf} \quad (3-5.8)$$

2) Equation of compatibility

The depth of the neutral axis is related to the depth of CGS by the similarity of the triangles in the strain diagram.

$$\frac{x_u}{d} = \frac{0.0035}{0.0035 + \epsilon_{pu} - \Delta\epsilon_p} \quad (3-5.9)$$

3) Constitutive relationships

a) Concrete

The constitutive relationship for concrete is considered in the expressions of C_{uw} and C_{uf} . This is based on the area under the design stress-strain curve for concrete under compression.

b) Prestressing steel

$$f_{pu} = F(\epsilon_{pu}) \quad (3-5.10)$$

The function $F(\epsilon_{pu})$ represents the design stress-strain curve for the type of prestressing steel used.

The known variables in an analysis are: b_f , b_w , D_f , d , A_p , $\Delta\epsilon_p$, f_{ck} and f_{pk} .

The unknown quantities are: A_{pf} , A_{pw} , M_{uR} , x_u , ϵ_{pu} and f_{pu} .

The objective of the analysis is to find out M_{uR} , the ultimate moment capacity. The simultaneous equations 3-5.1 to 3-5.10 can be solved iteratively.

The steps of the **strain compatibility method** are as follows.

- 1) Assume $x_u = D_f$.
- 2) The calculations are similar to a rectangular section, with $b = b_f$.
- 3) If $T_u > C_u$, increase x_u . Treat the section as a flanged section.
- 4) Calculate ϵ_{pu} from Eqn. (3-5.9).
- 5) Calculate f_{pu} from Eqn. (3-5.10).
- 6) Calculate A_{pf} and A_{pw} from Eqn. (3-5.7) and Eqn. (3-5.8), respectively.

- 7) Calculate C_{uw} , C_{uf} , T_{uw} and T_{uf} from Eqns. (3-5.1) to (3-5.4). If Eqn. (3-5.5) ($T_u = C_u$) is not satisfied, iterate with a new value of x_u , till convergence.
- 8) Calculate M_{uR} from Eqn. (3-5.6).

The capacity M_{uR} can be compared with the demand under ultimate loads. In the strain compatibility method, the difficult step is to calculate x_u and f_{pu} . Similar to the rectangular section, an approximate analysis can be done based on **Table 11** and **Table 12, Appendix B, IS:1343-1980**. The tables are reproduced in Table 3-4.1 and Table 3-4.2, respectively, in Section 3.4, Analysis of Member under Flexure (Part III).

The values of x_u and f_{pu} are available in terms of a reinforcement index ω_{pw} .

$$\omega_{pw} = \frac{A_{pw} f_{pk}}{b_w d f_{ck}} \quad (3-5.11)$$

Note that the index is calculated based on A_{pw} instead of A_p . The calculation of A_{pw} is from Eqn. (3-5.8). But A_{pf} depends on f_{pu} , which is unknown. Hence, an iterative procedure is required.

The steps are as follows.

- 1) Assume $f_{pu} = 0.87 f_{pk}$.
- 2) Calculate A_{pf} and A_{pw} from Eqn. (3-5.7) and Eqn. (3-5.8), respectively.
- 3) Calculate ω_{pw} .
- 4) Calculate f_{pu} from Table 11 or Table 12.

Compare the calculated value of f_{pu} with the assumed value. Repeat steps 1 to 4 till convergence.

- 5) Calculate M_{uR} .

If $D_f > (3/7) x_u$, the flange depth is larger than the depth of constant compressive stress. An equivalent depth of the flange is defined as follows.

$$y_f = 0.15 x_u + 0.65 D_f \quad (3-5.12)$$

The equivalent depth y_f is substituted for D_f in the expression of M_{uR} .

Example 3-5.1

A bonded post-tensioned concrete beam has a flanged cross-section as shown. It is prestressed with tendons of area 1750 mm^2 and effective prestress of 1100 N/mm^2 . The tensile strength of the tendon is 1860 N/mm^2 . The grade of concrete is M60.

Estimate the ultimate flexural strength of the member by the approximate method of IS:1343 - 1980.

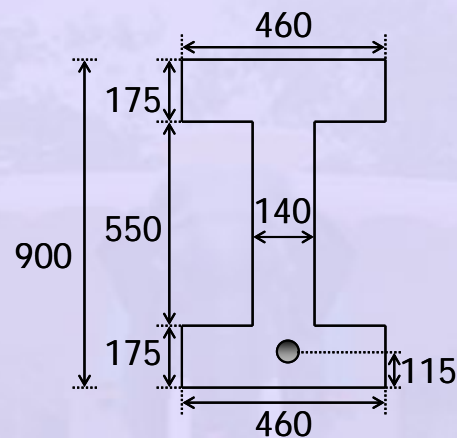

Values are in mm.

Cross-section at mid-span

Solution

$$\begin{aligned} \text{Effective depth } d &= 900 - 115 \\ &= 785 \text{ mm} \end{aligned}$$

Assume $x_u = D_f = 175 \text{ mm}$. Treat as a rectangular section, with $b = b_f = 460 \text{ mm}$.

Reinforcement index

$$\begin{aligned} \omega_p &= \frac{A_p f_{pk}}{b d f_{ck}} \\ &= \frac{1750 \times 1860}{460 \times 785 \times 60} \\ &= 0.15 \end{aligned}$$

$$\begin{aligned}
 T_u &= A_p f_{pu} \\
 &= 1750 \times 1618 \\
 &= 2831.5 \text{ kN}
 \end{aligned}$$

$$\begin{aligned}
 C_u &= 0.36 f_{ck} x_u b_f \\
 &= 0.36 \times 60 \times 175 \times 460 \\
 &= 1738.8 \text{ kN}
 \end{aligned}$$

$T_u > C_u$. Hence $x_u > D_f$

\Rightarrow Treat as a flanged section

Assume $f_{pu} = 0.87 f_{pk}$

$$= 1618 \text{ N/mm}^2$$

Calculate A_{pf} and A_{pw}

$$\begin{aligned}
 A_{pf} &= \frac{0.447 f_{ck} (b_f - b_w) D_f}{f_{pu}} \\
 &= \frac{0.447 \times 60 \times (460 - 140) \times 175}{1618} \\
 &= 934 \text{ mm}^2
 \end{aligned}$$

$$\begin{aligned}
 A_{pw} &= 1750 - 934 \\
 &= 816 \text{ mm}^2
 \end{aligned}$$

Reinforcement index

$$\begin{aligned}
 \omega_{pw} &= \frac{A_{pw} f_{pk}}{b_w d f_{ck}} \\
 &= \frac{816 \times 1860}{140 \times 785 \times 60} \\
 &= 0.23
 \end{aligned}$$

From Table 11,

$$\begin{aligned}
 \frac{f_{pu}}{0.87 f_{pk}} &= 0.92 \\
 f_{pu} &= 0.92 \times 0.87 \times 1860 \\
 &= 1489 \text{ N/mm}^2
 \end{aligned}$$

2nd iteration

$$f_{pu} = 1489 \text{ N/mm}^2$$

Calculate A_{pf} and A_{pw}

$$A_{pf} = \frac{0.447 \times 60 \times (460 - 140) \times 175}{1489}$$

$$= 1015 \text{ mm}^2$$

$$A_{pw} = 1750 - 1015$$

$$= 735 \text{ mm}^2$$

Reinforcement index

$$\omega_{pw} = \frac{735 \times 1860}{140 \times 785 \times 60}$$

$$= 0.21$$

From Table 11,

$$\frac{f_{pu}}{0.87f_{pk}} = 0.94$$

$$f_{pu} = 0.94 \times 0.87 \times 1860$$

$$= 1521 \text{ N/mm}^2$$

3rd iteration

$$f_{pu} = 1521 \text{ N/mm}^2$$

Calculate A_{pf} and A_{pw}

$$A_{pf} = \frac{0.447 \times 60 \times (460 - 140) \times 175}{1521}$$

$$= 994 \text{ mm}^2$$

$$A_{pw} = 1750 - 994$$

$$= 756 \text{ mm}^2$$

Reinforcement index

$$\omega_{pw} = \frac{756 \times 1860}{140 \times 785 \times 60}$$

$$= 0.21$$

The value of ω_{pw} is same as after 2nd iteration. Hence, the values of f_{pu} , A_{pf} and A_{pw} have converged.

Ultimate flexural strength

$$M_{uR} = T_{uw}(d - 0.42x_u) + T_{uf}(d - 0.5D_f)$$

$$\begin{aligned} T_{uw}(d - 0.42x_u) &= A_{pw}f_{pu}(d - 0.42x_u) \\ &= 756 \times 1521 \times (785 - 0.42 \times 337) \\ &= 739.9 \text{ kNm} \end{aligned}$$

$$\begin{aligned} T_{uf}(d - 0.5D_f) &= A_{pf}f_{pu}(d - 0.5D_f) \\ &= 994 \times 1521 \times (785 - 0.5 \times 175) \\ &= 1054.5 \text{ kNm} \end{aligned}$$

The ultimate flexural strength is given as follows.

$$\begin{aligned} M_{uR} &= 1054.5 + 739.9 \\ &= 1794.4 \text{ kNm} \end{aligned}$$

